

- S1210 – 1.21x1.21 m
- S1100 – 1.10x1.10 m

S1100

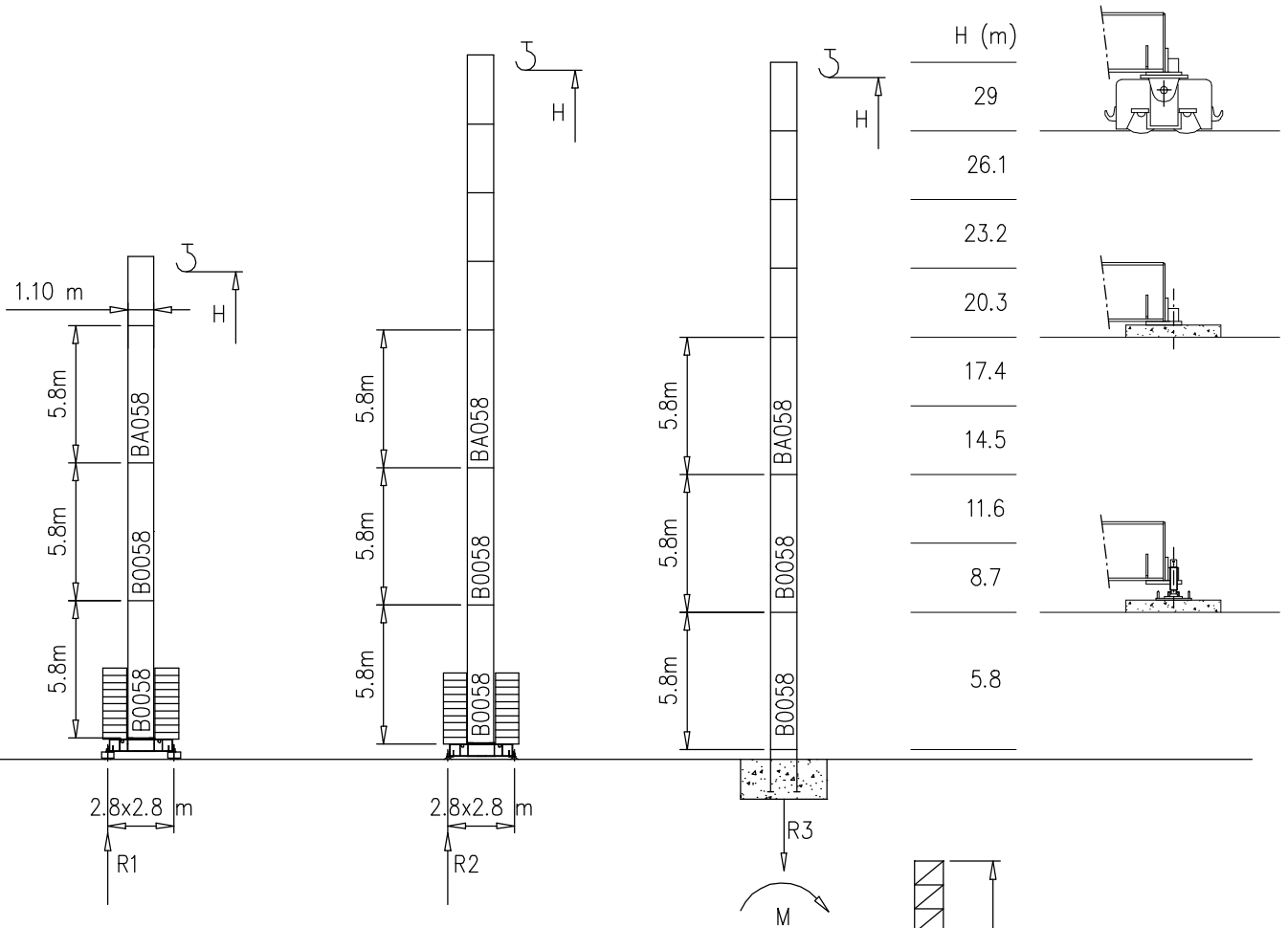

H=24–29 m		H=13–23 m		H=0–12 m	
R1		R1	21 t	R1	19 t
R2	23 t	R2	20 t	R2	18 t
R3	17 t	R3	16 t	R3	15 t
M	40 tm	M	32 tm	M	26 tm

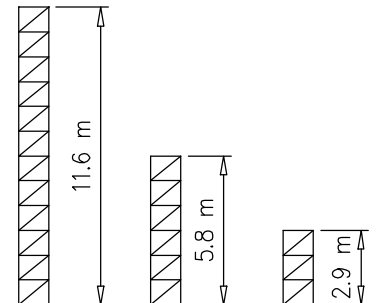

Peso zavorra – Ballast weight – Poids du lest – Ballastgewicht – Peso de lastre

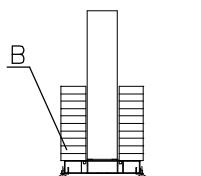

H	n°	Tot.
0–12 m	10 B	22000 kg
13–23 m	12 B	26400 kg
24–29 m	14 B	30800 kg

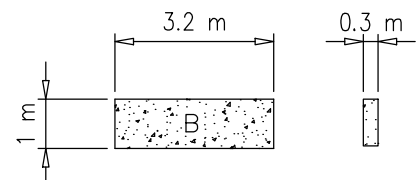

Curve di carico – Courbes de charges – Load diagrams – LastKurven – Curvas de cargas

Pmax 2400 kg

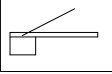
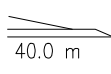
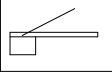
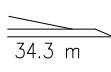
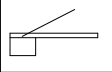
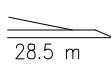
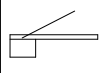
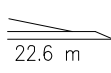
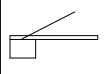
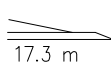
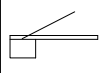
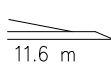
	7680 kg		2	18.5	22.6	28.5	34.3	40.0	m
			2400	2400	1930	1500	1220	1000	kg
	6600 kg		2	20.0	22.6	28.5	34.3		m
			2400	2400	2180	1680	1350		kg
	6030 kg		2		22.6	28.5			m
			2400		2400	1900			kg
	4950 kg		2		22.6				m
			2400		2400				kg
	4380 kg		2		17.3				m
			2400		2400				kg
	3300 kg		2		11.6				m
			2400		2400				kg

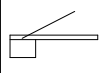
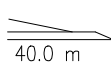
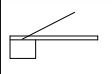
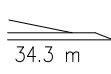
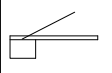
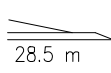
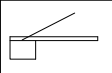
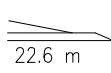
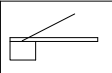
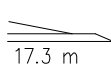
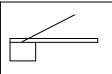
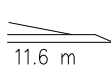

Pmax 2000 kg

	7680 kg		2		22.6	28.5	34.3	40.0	m
			2000		2000	1500	1220	1000	kg
	6600 kg		2		22.6	28.5	34.3		m
			2000		2000	1680	1350		kg
	6030 kg		2			28.5			m
			2000			2000			kg
	4950 kg		2		22.6				m
			2000		2000				kg
	4380 kg		2		17.3				m
			2000		2000				kg
	3300 kg		2		11.6				m
			2000		2000				kg



Montaggio – Montage – Erection – Montage – Montaje – Montagem







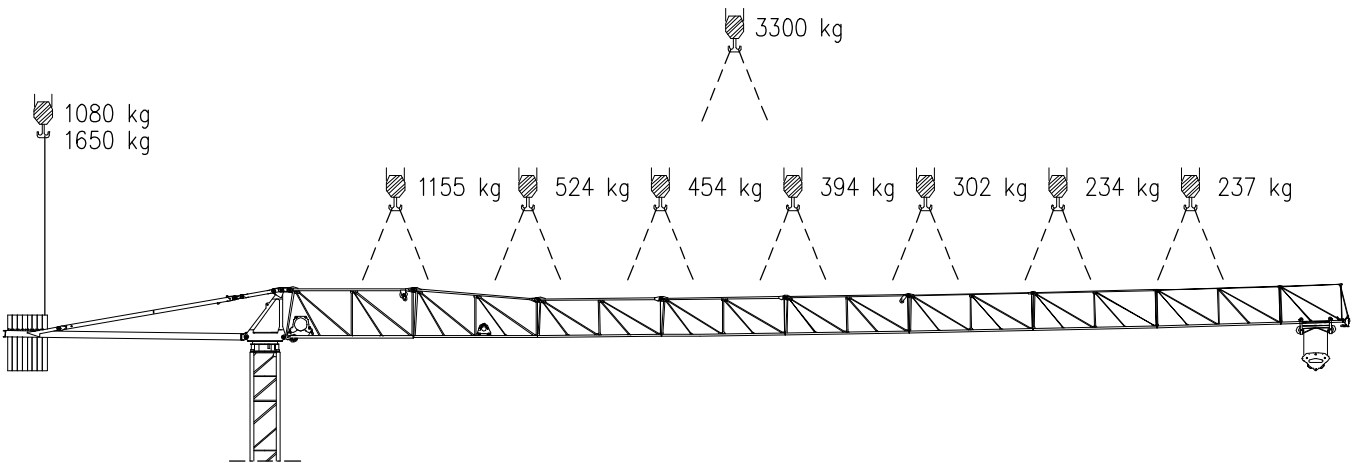
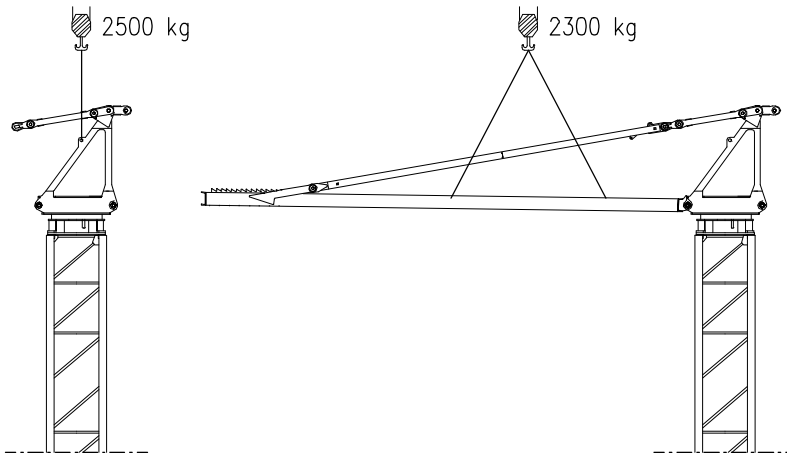
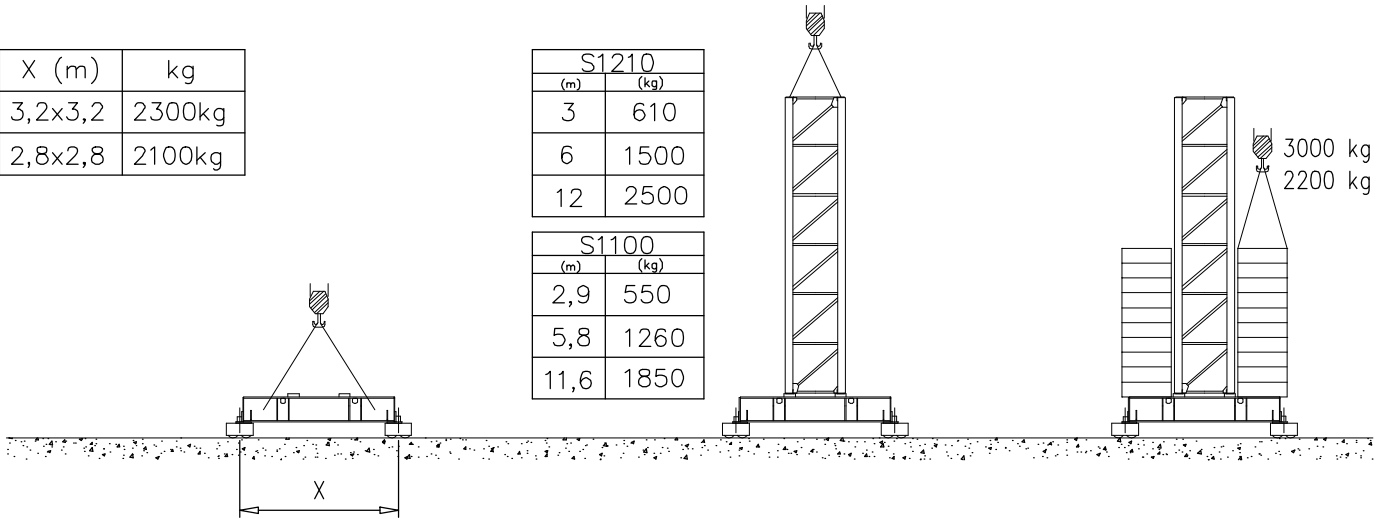

X (m)	kg
3,2x3,2	2300kg
2,8x2,8	2100kg

S1210	
(m)	(kg)
3	610
6	1500
12	2500

S1100	
(m)	(kg)
2,9	550
5,8	1260
11,6	1850



Meccanismi – Mechanisms – Mécanismes – Antriebe – Mecanismos

Sollevamento M07.47 Hoisting Levage Heben Elevaciòn Elevaçao		1a	3 m/min	2400 kg	7.5 kW	22kVA	
		2a	16 m/min	2400 kg			
		3a	36 m/min	1000 kg			
		4a	40 m/min	800 kg			
		5a	47 m/min	400 kg			
Sollevamento V07.36 Hoisting Levage Heben Elevaciòn Elevaçao		1a	3 m/min	2000 kg	7.5 kW	22kVA	
		2a	16 m/min	2000 kg			
		3a	* 26 m/min	1500 kg			
		4a	36 m/min	1000 kg			
		5a	* 38 m/min	600 kg			
		* Optional					
Carrello Trolleying Distribution Katzfahren Distribuciòn Distribuiçao			1a	5 m/min	2400 kg	1.5 kW	Potenza elettrica necessaria Puissance électrique nécessaire Necessary electric power Anschlusswert – Potencia
			2a	17 m/min	2400 kg		
			3a	34 m/min	2000 kg		
Rotazione Slewing Orientation Schwenken Orientaciòn Rotaçao			1a	0 → 0.2	giri/min tr/min rp/min	4 kW	
			2a	0 → 0.4			
			3a	0 → 0.7			
Traslazione Travelling Translation Kranfahren Traslaciòn Translaçao			1a	0 → 8	m/min	3.7 kW	
			2a	0 → 18			

Rete elettrica – Réseau – Mains supply – Netzstrom – Red – Rede electrica	400V – 50 Hz
	480V – 60 Hz

**AFM Gru** FMgru s.r.l.  
via Emilia 11-29010 Pontenure PC ITALY  
tel. 0523/510446 ric.aut. fax 0523/510365  
www.fmgru.com e-mail: info@fmgru.com

FEM 1.001  
2000/14/CE



Documento commerciale non contrattuale  
Per tutte le informazioni tecniche riferirsi  
alle corrispondenti istruzioni

Unverbindliches Vertriebsdokument.  
Für technische Informationen, siehe die  
entsprechenden Anweisungen.

This commercial document is not legally  
binding. For any technical information, please  
refer to the corresponding instructions.

Documento commercial no contractual  
Para cualquier información técnica,  
ver la noticia correspondiente.

Code: 15ICA37T15A0			
Ed.	Data	Rev	Data
1	15.04.04	1	12.04.05